

# Design and Implementation of a Three-Phase Asynchronous Motor Drive Based on a Single Chip Three-Phase Bridge Driver IR 2132

Derian Endo Amandus<sup>1</sup>, Slamet Riyadi<sup>2</sup>, Leonardus Heru Pratomo<sup>3</sup>  
<sup>1,2,3</sup>Dept. of Electrical Engineering, Soegijapranata Catholic University, Semarang, Indonesia

## Article Info

### Article history:

Received Jul 15, 2023  
Revised Oct 25, 2023  
Accepted Dec 02, 2023

### Keywords:

Asynchronous motor  
Three-phase inverter  
SPWM

## ABSTRACT

Technological developments in this world are growing quite rapidly, one of which is the development of the use of electric motors. There are many types of electric motors today, for example asynchronous electric motors or often called induction motors. In its use, asynchronous motors are widely used on an industrial scale. As time went by, asynchronous motor control itself also began to develop, starting from mechanically using switches to using inverters. The use of a three-phase IGBT inverter to control a three-phase asynchronous motor will be discussed in this research. The inverter control itself will use the SPWM topology, where the SPWM topology has advantages over the PWM topology. Apart from that, this research will use a single chip three-phase bridge driver IR2132 as the IGBT driver. This IC has advantages, one of which is that it has an internal deadtime, where deadtime is very necessary in controlling the three-phase inverter so that short circuits do not occur between the legs. This research shows that with a certain DC Link input voltage, it is possible to regulate a three-phase asynchronous motor using SPWM topology to control an IGBT inverter.

*This is an open access article under the [CC BY](#) license.*



## Corresponding Author:

Derian Endo Amandus,  
Department of Electrical Engineering,  
Soegijapranata Catholic University,  
Semarang, Indonesia.  
Email: endoderian@gmail.com

## 1. INTRODUCTION

Technological developments in the world today are growing quite rapidly in various fields of life. One example is the development of the use of electric motors in certain fields. There are various types of electric motors currently, for example asynchronous electric motors or often called induction motors. Asynchronous motors are often used in various fields such as industry to automotive [1][2]. Because this type of electric motor has several advantages over other types of electric motors, such as good efficiency, high reliability, simple design, easy control and can be integrated with modern technology.

As the use of asynchronous motors has grown, various techniques for managing the operation of asynchronous motors have emerged. [3][4]. Starting from the simplest method, namely mechanically using an ON/OFF switch to using an inverter as a speed controller for asynchronous motors [5]. The development of inverter topology itself has also developed quite a bit over time. With the discovery of super-fast semiconductor static switches in the field of power electronics, developments in inverter control techniques themselves were made [6]. On the other

hand, the development of complex control techniques based on digital single chips is also a factor in this. Initially the inverter was designed analogue with a fairly complex and complicated hardware circuit, but it had a fairly fast response and was very sensitive to interference from outside the system, which was a factor in the shortcomings of the analog system [7][8]. So currently a single chip digital based system is being developed to replace the previous analog system.

In the development of digital-based systems, the simplest inverter topologies are starting from square wave inverters, PWM (Pulse Width Modulation), and SPWM (Sinusoidal Pulse Width Modulation). In this research, we will control a three-phase asynchronous motor using an inverter topology with the SPWM (Sinusoidal Pulse Width Modulation) technique. Because the SPWM (Sinusoidal Pulse Width Modulation) technique has advantages over the PWM (Pulse Width Modulation) technique which has high distortion or ripples in the output wave [9][10]. Using semiconductor components controlled by a single chip three phase bridge driver IR2132. In addition, the aim of this research is to utilize a single-phase power source to regulate a three-phase asynchronous motor [11].

## 2. RESEARCH METHOD

### 2.1. Three-Phase Asynchronous Motor

Three-phase asynchronous motors are a type of electric motor which are usually called induction motors. This three-phase asynchronous motor is widely used in the industrial sector to drive industrial factory machines such as conveyor machines, elevators and so on [12][13]. The many applications of asynchronous motors are because these motors have advantages over other types of motors such as having high efficiency, lower usage costs, can be operated on various power sources, are easy to control and can be integrated with modern technology.

Asynchronous motors require a three-phase voltage source to drive them, the phase difference causes a rotating force in the asynchronous motor. When applying a three-phase power supply to an asynchronous motor, the stator windings generate a magnetic field that rotates synchronously, maintaining a constant magnitude when shifted by  $120^\circ$ . The operational concept of an asynchronous motor is rooted in Faraday's law, which states that the magnitude of the induced current in a closed circuit is directly proportional to the magnetic flux through it. A schematic representation of an asynchronous motor is depicted in Fig 1.

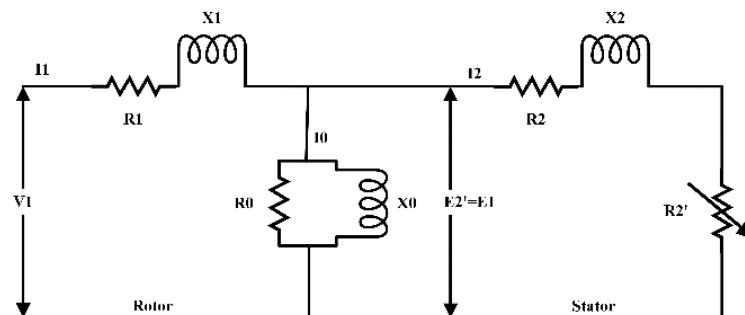

Fig 1. Asynchronous motor schematic circuit

The speed of an asynchronous motor can be regulated based on frequency or input voltage as in Equation (1) below.

$$I = \frac{V}{\omega L} = \frac{V}{2\pi f L} \quad (1)$$

I indicates the transit current, the motor power source requirement is represented by V. Simultaneously,  $\omega$  (omega) indicates the rotation speed of the motor, and L means the induction value of the motor. Changes in input frequency and voltage values for asynchronous motors must be synchronous to maintain consistent current, regardless of changes in motor speed.

### 2.2. Three-Phase Inverter Topology

An inverter is an electronic device that has the function of changing a DC source into an AC source. Applications of inverters range from industry, automotive to renewable energy power plants. Apart from converting a DC source into an AC source, inverters are also often used to control asynchronous or induction motors. The reason why three-phase inverters are widely used in industrial environments as asynchronous motor controllers is because of their advantages compared to mechanical control of asynchronous motors using ON/OFF switches. Three-phase inverters allow adjusting the rotation speed of the asynchronous motor as necessary [14]. In addition, the use of a three-phase inverter does not depend on the availability of a three-phase power supply.

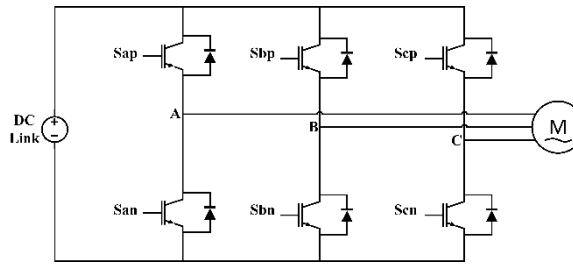

Fig 2. Skema three-phase inverter

The three-phase inverter consists of six static switches, operated by regulating the switching of the six static switches as in Fig 2. Each pair of switches is operated in reverse. This inverter has three legs, namely legs A, B and C. Where in each leg there are two static switches, namely on leg A ( $S_{ap}$ ,  $S_{an}$ ), leg B ( $S_{bp}$ ,  $S_{bn}$ ) and leg C ( $S_{cp}$ ,  $S_{cn}$ ). The two switches on the same leg must be complementary and must not conduct or turn on together which will cause a short circuit, but the continuity of the AC side current must be maintained.

The six-step inverter topology is the simplest topology, so in making the SPWM inverter topology, the six-step topology is used as the basis. In Fig 3 is the operating mode of the six-step topology, there are eight possible operating modes of the three phase three leg inverter.

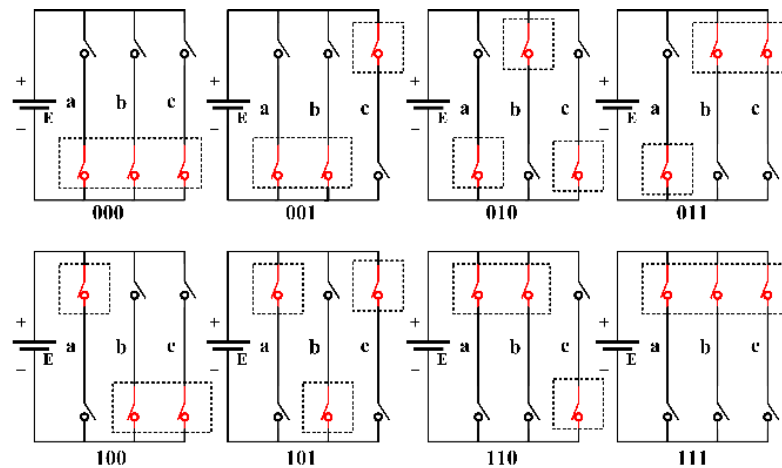

Fig 3. Three-phase inverter switching configuration.

For example, when the configuration is 000, it means the switch is on  $S_{an}$ ,  $S_{bn}$  and  $S_{cn}$  so that points a, b and c will be connected to the negative terminal of the DC Link voltage source. In this condition, the value  $V_{ab} = V_{bc} = V_{ca} = 0$ . The eight configurations are presented in table form as in Table 1 below.

Table 1. Three-phase inverter status of switches

$S_{ap}$	$S_{bp}$	$S_{cp}$	$V_{ab}$	$V_{bc}$	$V_{ca}$	Vector	
1	0	0	E	0	-E	V1	On
1	1	0	0	E	-E	V2	On
0	1	0	-E	E	0	V3	On
0	1	1	-E	0	E	V4	On
0	0	1	0	-E	E	V5	On
1	0	1	E	-E	0	V6	On
1	1	1	0	0	0	V7	On
0	0	0	0	0	0	V0	Off

Fig 4 below provides an overview of inverter operation using a six-step inverter topology with a control signal at the gate. The output voltage is a square wave that fluctuates positive, zero and negative.

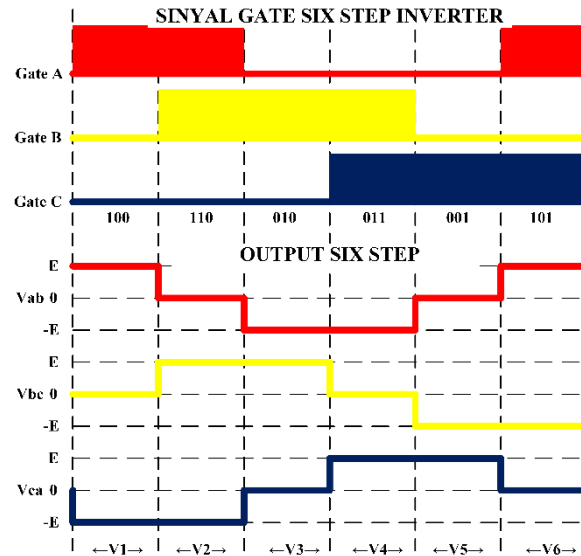

Fig 4. Gate signal and inverter output voltage with six step inverter topology

**2.3. Single Chip Three-Phase Bridge Driver**

A single-chip three-phase bridge driver is a high-voltage, high-speed driver for a MOSFET or IGBT, featuring three separate or individual output legs. Using the IR 2132 driver as a three-phase inverter power circuit has advantages and disadvantages, such as only needing one 12 Volt power supply to supply all optocoupler components and the IR 2132 driver, this driver hardware is smaller so it is more compact. Apart from that, the most important thing is that the IR 2132 IC has internal deadtime so it does not require an external deadtime circuit, where deadtime is very necessary in operating the static switch on a three-phase inverter. To avoid short circuits, the top and bottom switches must remain on alternately. Fig 5 is a schematic circuit of the Ir2132 driver.

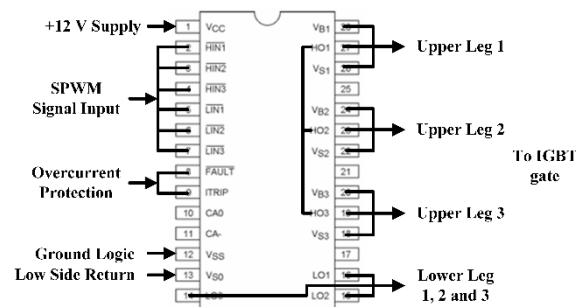

Fig 5. IR2132 driver schematic circuit

**2.4. SPWM Signal Generation**

Utilizing PWM (Pulse Width Modulation) signals to regulate the inverter output voltage and frequency involves managing the duration of the output signal pulses [15]. PWM signals have the weakness of producing high harmonics in the output wave. To overcome this problem, an inverter control method was developed using SPWM (Sinusoidal Pulse Wide Modulation) signals. With more sophisticated signal processing than PWM, the output signal waveform from SPWM resembles a sinusoidal wave, has a smoother curve and the resulting harmonics are not as high as the PWM signal wave [16][17].

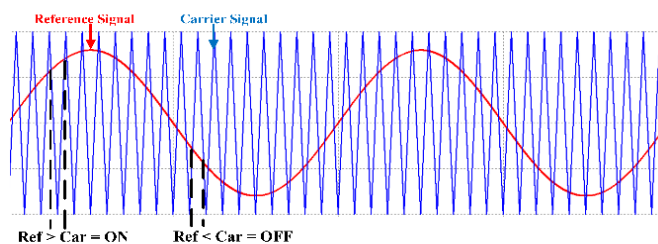

Fig 6. Comparison of reference and carrier signal waveform

The SPWM signal waveform emerges from a comparison between the reference signal (sinusoidal wave) and the carrier wave (triangular wave), as depicted in Fig 6. When the magnitude of the sinusoidal wave exceeds that of the triangular wave, this causes a larger resultant pulse, and vice versa [18].

The SPWM control technique is a way to regulate an asynchronous motor by adjusting the switching duration to control the output voltage and frequency [19]. Equation (2) is a calculation of the sinusoidal pulse width modulation index. On the other hand, the resulting output voltage depends on the results of the modulation index, making it possible to calculate the amplitude produced by the SPWM according to Equation (3).

$$M (\text{modulation index}) = \frac{V_{\text{reference}}}{V_{\text{carrier}}} \tag{2}$$

$$V_{\text{ac output}} = \frac{\text{DC Link}}{2} \tag{3}$$

A three-phase SPWM signal is generated by comparing three reference signals shifted 120° to the carrier signal. Changing the SPWM frequency will result in a proportional adjustment to the frequency and voltage by modifying the duty cycle.

**2.5. System Block Diagram**

This research planning includes the design and implementation of drivers for three-phase asynchronous motor control. The hardware used is as in Fig 7, consisting of a power supply as a power source, a dsPIC30f4012 microchip as a microcontroller, an IGBT driver circuit as an inverter controller, and a three-phase IGBT inverter. The power circuit switch uses IGBT (Insulated Gate Bipolar Transistor), which can operate effectively at high levels of voltage and current. While the use of a dsPIC30f4012 microchip to handle SPWM algorithm programming, this microcontroller has a high level of performance for generating SPWM signals.

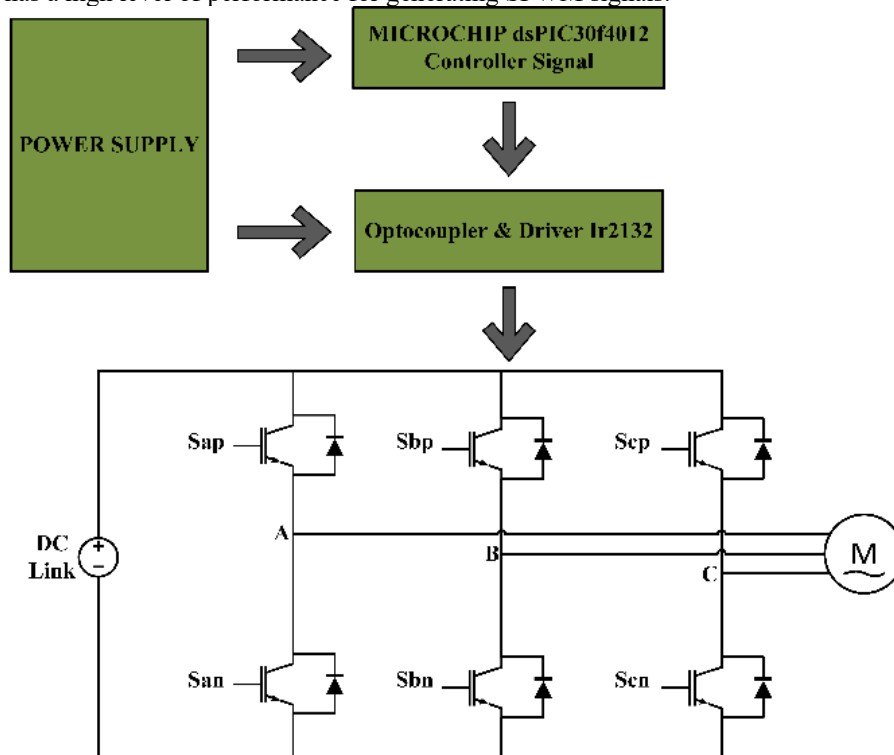

Fig 7. Hardware block diagram

**2.6. SPWM Algorithm**

The implementation of the SPWM signal generation programming algorithm is illustrated through the flowchart in Fig 8. From the flow diagram above, it can be explained that the beginning of the program is initializing constants and variables, lookup table to generate information signals (sinusoidal), timer and interrupt for carrier signals. Then it is divided into three legs, namely phase A, phase B and phase C. If the phase value is smaller than the carrier then it is the same as high, conversely if the phase value is greater than the carrier then it is the same as low. The output of the program is the SPWM signal which is used for inverter switching.

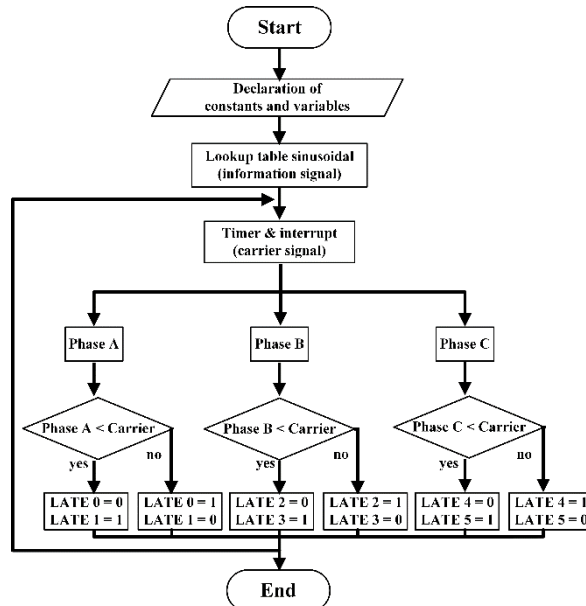

Fig 8. SPWM flowchart

### 3. RESULTS AND DISCUSSIONS

The hardware design implementation in this research is as shown in Fig 9, using a three-phase asynchronous motor with an IGBT inverter as the motor controller. Apart from that, there is also an IGBT Ir2132 driver and a dsPIC30f4012 microcontroller as an SPWM signal generator. There is a DC power supply as a DC voltage source.

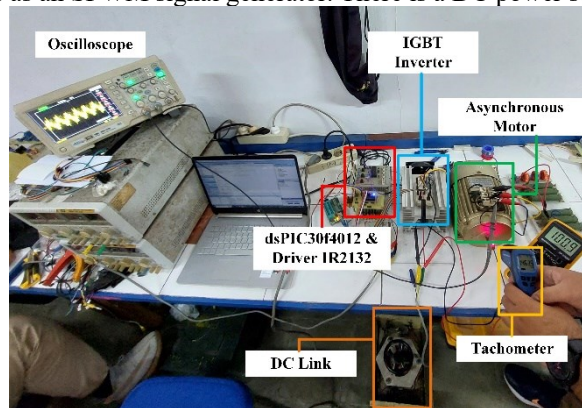

Fig 9. Hardware for experimental works

After implementing it on the hardware, the SPWM signal is then generated using a microcontroller using a basic six step inverter topology. Fig 10 is the waveform results for the upper and lower legs. Due to the operation of a three-phase inverter, the upper and lower legs must complement each other and not turn on simultaneously.

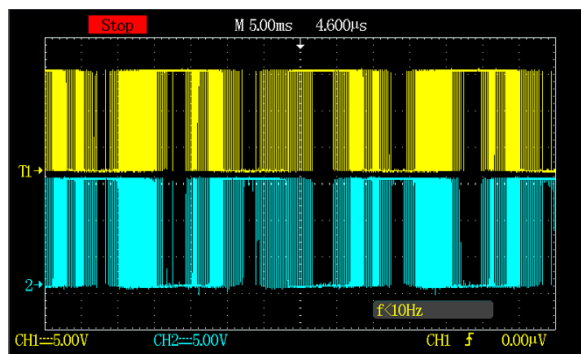

Fig 10. Experimental signal waveform output for the upper and lower legs

The SPWM wave is then fed into the IGBT driver circuit. The IGBT driver in this study uses a single chip three phase bridge driver IR2132 IC where there is internal deadtime in the IC. So, it doesn't require an external deadtime circuit or so on in its use. Fig 11 shows the deadtime results seen on the oscilloscope. The deadtime value contained in the IR2132 IC is 0.7µs, this deadtime value is suitable for the IGBT inverter switching operating system used.

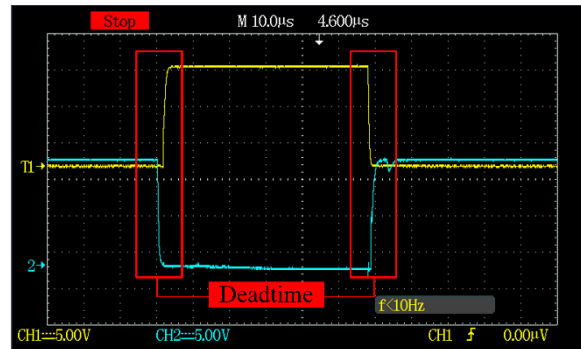

Fig 11. Deadtime provided by IR2132

Table 2. IR2132 features and specifications

Feature	Specification
V offset	600 VDC max
Working Voltage Rating	up to 20 V
Gate Output Voltage	up to 20 V
Internal Deadtime	0,7µs
Protection	overcurrent & undervoltage

As an illustration of the features and specifications of the IR2132 IC, they are as shown in Table 2. The IR2132 has a maximum offset voltage of 600 VDC, with a working voltage rating and gate output voltage of up to 20 volts. Has overcurrent and undervoltage protection. Meanwhile, the value of the IR2132 internal deadtime is 0.7µs.

In the context of this research, the specifications of the asynchronous motor used as an example are detailed in Table 3. The asynchronous motor has a power of 375 watts, with a voltage and current of 380 volts and 1.08 amperes respectively. It can reach a maximum rotation speed of 1400 rpm at a peak frequency of 50 Hz. Meanwhile, this motorbike weighs 10 kg.

Table 3. Asynchronous motor specifications

Model	YS7124	Model
Power	375	W
Voltage	380	V
Current	1,08	A
Maximum Speed	1400	Rpm
Maximum Frequency	50	Hz
Massa	10	Kg

Figure 12 illustrates the conditions where the asynchronous motor operates at a certain DC Link input voltage while rotating at a speed of 1400 rpm. By using an IGBT inverter which has been controlled using SPWM switching from the microcontroller and IGBT driver.

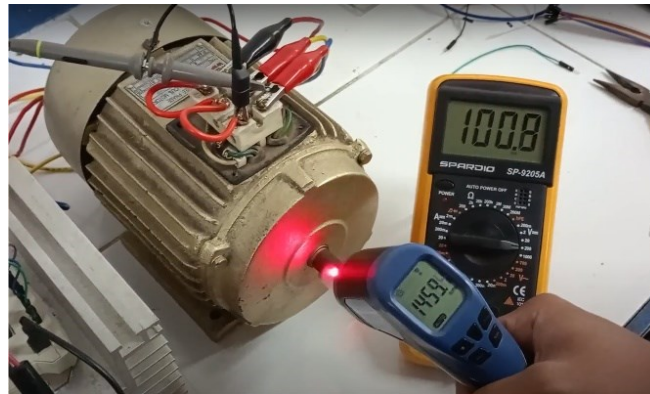

Fig 12. Speed measurement of the prototype

In this research experiment, we will measure and observe the output waveform on the prototype. Voltage waveform measurements are carried out at the input terminal of a three-phase asynchronous motor using a voltage probe and a current probe. Starting from measuring phase voltage with neutral, then measuring phase voltage with phase, and finally measuring phase voltage and current with neutral.

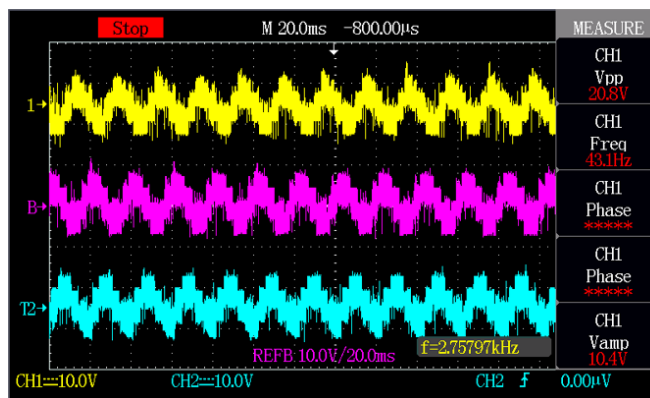

Fig 13. Experimental results of induction motor output phase voltage of inverter

Fig 13 displays the phase-neutral measurement results for the three-phase voltage waveform. On the other hand, Fig 14 represents the phase-phase measurement results for three-phase voltage waveforms.

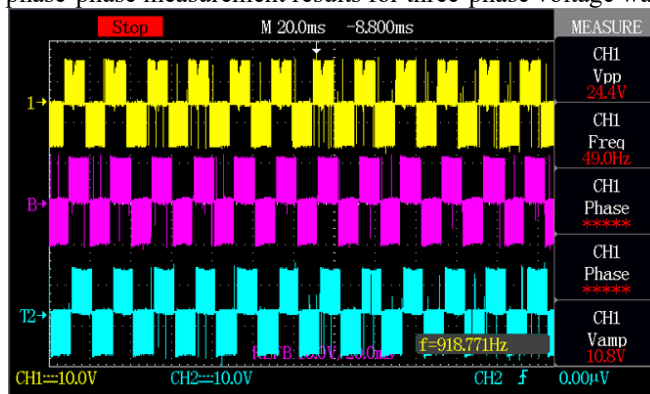

Fig 14. Experimental results of induction motor output line voltage of inverter

Next, Fig 15 depicts the results of measuring the voltage and current waveforms at the input of a three-phase asynchronous motor. This measurement is carried out using a voltage probe and a current probe from a single phase oscilloscope. In the waveform results, it can be seen that the current waveform appears after the voltage waveform. This condition is called lagging because asynchronous motors have inductive components.



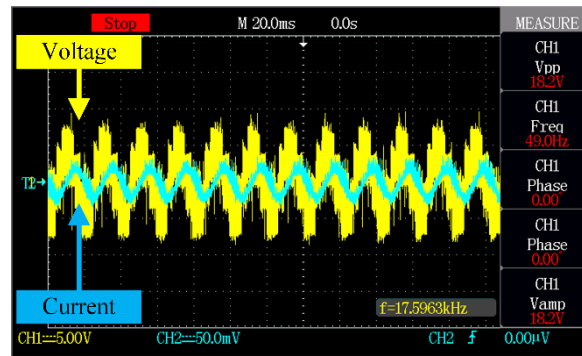

Fig 15. Experimental results of phase voltage and current of the inverter

#### 4. CONCLUSION

From the research experiments that have been carried out, several conclusions can be drawn, including that the use of SPWM (Sinusoidal Pulse Wide Modulation) waves as a three-phase inverter control topology has advantages compared to using PWM (Pulse Wide Modulation) waves. The use of a single-chip three-phase IR2132 bridge driver in this research shows that this IC has an internal deadtime of  $0.7\mu\text{s}$ , where deadtime in SPWM wave generation is very necessary in the operation of the IGBT inverter so that there is no short circuit between the inverter switches.

#### ACKNOWLEDGEMENTS

This work was supported by Directorate of Research, Technology and Community Service, Directorate General of Higher Education, Research and Technology, The Ministry of Education, Culture, Research and Technology, Republic of Indonesia under the scheme of PTUPT 2023 number 0217/E.5/PG.02.00/2023

#### REFERENCES

- [1] Institut Teknologi Bandung. Fakultas Teknologi Industri. Instrumentation and Control Research Group, Institute of Electrical and Electronics Engineers. Indonesia Section, Institute of Electrical and Electronics Engineers. Indonesia Section. CSS/RAS Joint Chapter, and Institute of Electrical and Electronics Engineers, *Proceedings of the 2019 6th International Conference on Instrumentation, Control, and Automation (ICA) : Bandung, Indonesia, 31 July - 2 August 2019*.
- [2] Mahawitthayalai Songkhlanakharin. College of Computing, C. Electrical Engineering/Electronics, IEEE Thailand Section, and Institute of Electrical and Electronics Engineers, *The 17th International Conference on Electrical Engineering/Electronics, Computer, Telecommunications and Information Technology: ECTI-CON 2020 : 24-27 June 2020, virtual conference hosted by College of Computing, Prince of Songkla University*.
- [3] JCT College of Engineering and Technology and Institute of Electrical and Electronics Engineers, *Proceedings of the 4th International Conference on Inventive Systems and Control (ICISC 2020) : 8-10 January, 2020*.
- [4] R. Pandey, A. K. Panda, and N. Patnaik, "Comparative Performance Analysis of DTC fed Three-Phase and Five-Phase Induction Motor," in *ICDCS 2020 - 2020 5th International Conference on Devices, Circuits and Systems*, Institute of Electrical and Electronics Engineers Inc., Mar. 2020, pp. 162–166. doi: 10.1109/ICDCS48716.2020.243572.
- [5] A. Sudaryanto *et al.*, "Design and Implementation of SVPWM Inverter to Reduce Total Harmonic Distortion (THD) on Three Phase Induction Motor Speed Regulation Using Constant V/F," in *2020 3rd International Seminar on Research of Information Technology and Intelligent Systems, ISRITI 2020*, Institute of Electrical and Electronics Engineers Inc., Dec. 2020, pp. 412–417. doi: 10.1109/ISRITI51436.2020.9315353.
- [6] B. S. S. G. Yelamarthi and S. R. Sandepudi, "Scalar Control of Induction Motor Drive with Inverter Fault-Tolerance Capability," in *2020 International Conference on Emerging Frontiers in Electrical and Electronic Technologies, ICEFEET 2020*, Institute of Electrical and Electronics Engineers Inc., Jul. 2020. doi: 10.1109/ICEFEET49149.2020.9187013.
- [7] B. Benhala, Jami'at al-Mawlāy Ismā'īl. Faculty of Sciences, Institute of Electrical and Electronics Engineers. Morocco Section, and Institute of Electrical and Electronics Engineers, *IRASET'2020 : 2020 1st International Conference on Innovative Research in Applied Science, Engineering and Technology (IRASET) : March 19-20, 2020, Faculty of Sciences, Meknes University of Moulay Ismail - Morocco*.
- [8] *2018 International Conference on Smart Electric Drives and Power System (ICSEDPS)*. IEEE.
- [9] J. W. Rengifo and J. M. Aller, "An efficiency estimation method for inverter fed induction motors," in *Proceedings - 2021 IEEE Workshop on Electrical Machines Design, Control and Diagnosis, WEMDCD 2021*,

- Institute of Electrical and Electronics Engineers Inc., Apr. 2021, pp. 22–27. doi: 10.1109/WEMDCD51469.2021.9425682.
- [10] R. Sarker, A. Datta, and S. Debnath, “FPGA-Based High-Definition SPWM Generation with Harmonic Mitigation Property for Voltage Source Inverter Applications,” *IEEE Trans Industr Inform*, vol. 17, no. 2, pp. 1352–1362, Feb. 2021, doi: 10.1109/TII.2020.2983844.
- [11] V. V. Kharlamov, Y. V. Moskalev, and V. S. Lysenko, “Simulation of the Electrical Phase Converter Connecting a Three-Phase Motor to A Single-Phase Network,” in *14th International IEEE Scientific and Technical Conference Dynamics of Systems, Mechanisms and Machines, Dynamics 2020 - Proceedings*, Institute of Electrical and Electronics Engineers Inc., Nov. 2020. doi: 10.1109/Dynamics50954.2020.9306160.
- [12] Institute of Electrical and Electronics Engineers, *SPEEDAM 2020 - proceedings : International Symposium on Power Electronics, Electrical Drives, Automation and Motion : virtual meeting, June 24th-June 26th*.
- [13] T. V, Vellore Institute of Technology, Institute of Electrical and Electronics Engineers. Madras Section, IEEE Communications Society., and Institute of Electrical and Electronics Engineers, *Conference proceedings, International Conference on Vision Towards Emerging Trends In Communication and Networking (ViTECoN 2019) : 30-31, March 2019, Vellore, Tamilnadu, India*.
- [14] R. K. Antar, N. S. Sultan, and A. J. Ali, “Speed Control of Three-Phase Induction Motor Fed by Renewable Energy Source,” in *2nd International Conference on Electrical, Communication, Computer, Power and Control Engineering, ICECCPCE 2019*, Institute of Electrical and Electronics Engineers Inc., Feb. 2019, pp. 7–12. doi: 10.1109/ICECCPCE46549.2019.203739.
- [15] M. Mahbub, “Comparative Analysis of Five Different PWM Techniques on Three-Phase Voltage Source Inverter fed Induction Motor Drive,” in *International Conference on Robotics, Electrical and Signal Processing Techniques*, 2021, pp. 6–11. doi: 10.1109/ICREST51555.2021.9331234.
- [16] I. M. Al-Adwan and Y. A. Al Shiboul, “Effect of the Modulation Index and the Carrier Frequency on the Output Vol Tage Waveform of the Spwm Voltage Source Inverter,” in *Proceedings of the 17th International Multi-Conference on Systems, Signals and Devices, SSD 2020*, Institute of Electrical and Electronics Engineers Inc., Jul. 2020, pp. 960–968. doi: 10.1109/SSD49366.2020.9364104.
- [17] A. Ben Rhouma and M. Hamouda, “DSP Implementation of a Novel SPWM Algorithm Dedicated to the Delta Inverter,” in *Proceedings - STA 2020: 2020 20th International Conference on Sciences and Techniques of Automatic Control and Computer Engineering*, Institute of Electrical and Electronics Engineers Inc., Dec. 2020, pp. 195–200. doi: 10.1109/STA50679.2020.9329297.
- [18] P. N. Astya, M. Singh, Institute of Electrical and Electronics Engineers, Institute of Electrical and Electronics Engineers. Uttar Pradesh Section, and Sharda University. School of Engineering and Technology, *IEEE 2019 International Conference on Computing, Communication, and Intelligent Systems (ICCCIS) : proceedings : on 18th-19th Oct, 2019*.
- [19] *2019 International Seminar on Application for Technology of Information and Communication (iSemantic)*. IEEE, 2019.