

## Fault Detection Analysis in Ball Bearings using Machine Learning Techniques

Chandan D. Chaudhari, Chinmayee Chogale, Dwij Iyer, Shubham Junghare, Vedant Surve

Department of Mechanical Engineering  
SIES Graduate School of Technology  
Mumbai, India

---

### Article Info

#### Article history:

Received Jun 2, 2023  
Revised Jun 18, 2023  
Accepted July 24, 2023

#### Keywords:

Misalignment  
Fault Detection  
Bearing  
Machine Learning

---

### ABSTRACT

The Bearing element is very essential component of any rotating equipment. Any defect in the bearings lead to instable performance of the machinery. To avoid such malfunction and breakdown of the machinery equipment due to misalignment is review critically in this research paper and various machine learning techniques to tackle the issue is highlighted. This review article finds the basis for developing an effective system in order to reduce the breakdown of machinery or equipment. Conventional Machine Learning methods, like Artificial neural network, Decision Tree, Random Forest, Support Vector Machines (SVM) have been applied to detecting categorizing fault, while the application of Deep Learning methods has ignited great interest in the industry.

*This is an open access article under the [CC BY](https://creativecommons.org/licenses/by/4.0/) license.*



---

### Corresponding Author:

Shubham Junghare,  
Department of Mechanical Engineering  
SIES Graduate School of Technology,  
Mumbai, India.  
Email : shubhamtjunghare@gmail.com

---

## 1. INTRODUCTION

In the recent years, condition monitoring and fault diagnosis of equipment are of great concern in industries. Timely Fault analysis in machineries can save millions of dollars in maintenance cost. In rotating machineries, bearings are one of the most critical components because they are the most commonly wearing parts and a large majority of system failures arise from faulty bearings. Proper working of these elements is extremely important in industry in order to prevent long term costly downtimes. It is obvious that more attention must be paid to the condition of a rolling element bearing if the human life is in question. Thus, an advanced technology is needed to monitor the health status of bearings efficiently and effectively.

Roller bearings consists of different parts: an outer-race, an inner-race, roller-elements that are in contact under heavy dynamic loads and relatively high speeds, and optionally a cage around these rolling elements. Faults may occur in any of these parts, and often these faults are single point defects such as chips or dents. As these elements move past each other, these defects come into periodic contact with other elements in the bearing, and at each contact they can excite a high frequency resonance in the overall structure. Bearing damage may result in a complete failure of the bearing however, in a reduction in operating efficiency of the bearing arrangement. Only if operating and environmental conditions as well as the details of the bearing arrangement are completely in tune, can the bearing arrangement operate efficiently. In the recent years, manufacturers have been concentrating on finding out techniques in order to improve the bearing designs.

Researchers are using various approaches like mathematical models, computer aided engineering (CAE) based simulation models' experimental models. The purpose of this paper is to give details of the different measurement techniques in the last period on bearing defects. Different methodologies for detection and diagnosis of bearing defects:

- Vibration measurements
- Acoustics measurement technique
- Temperature measurements
- Wear debris analysis

A significant portion of the papers on the fault diagnosis of induction machines are dealing with on the faults of rolling bearings. Even though that vibration-based condition monitoring techniques are usually applied for the diagnosis of the bearings, many papers use the stator current analysis, due to its advantages. The methods used for stator current analysis decompose and analyse the signal using various techniques such as Fourier analysis, neural networks, wavelets, statistical analysis, etc.

This paper deals with the fault detection and diagnosis for a class of rolling-element bearings using signal-based methods based on the motor's vibration and phase current measurements, respectively. The envelope detection method is employed to pre-process the measured vibration data before the FFT algorithm is used for vibration analysis. The average of a set of Short-Time FFT (STFFT) is used for the current spectrum analysis. A set of fault scenarios, including single and multiple point- defects as well as generalized roughness conditions, are designed and tested under varying operational conditions, including varied motor speeds, differing load condition and data from different operating time intervals.

Timely fault detection plays an important role in high-cost and safety-critical processes. Early Detection of process faults helps to avoid abnormal event progression. This paper deals with the literature survey of methodologies and current state of research on the topic with selection of important practical application.

## 2. LITERATURE REVIEW

Junning Li et.al [1], presented a research article in which a test rig was made to assess the skidding damage of the roller bearing under different working conditions.

Five parameters were considered for the results and their observations were as follows.

1. Effect of the Radial Load on the Slip Rate and Temperature. The speed of the inner ring is 1050 r/min; amount of oil used for lubrication 5 mL/min; the Load applied radially is 70 N, 100 N, 130 N 160 N, and 190 N.
2. Effect of the Inner Ring Speed on the Slip Rate and Temperature. Load applied radially is 130 N; quantity of oil used for lubrication is 5 mL/min; the inner ring speeds are 1050 r/min, 1230 r/min, 1410 r/min, 1590 r/min, and 1770 r/min.
3. The minimum measured load is 125 N while the benchmark is 130 N, and the error of them is 3%.
4. Effect of the Lubricating Oil Quantity on the Slip Rate and Temperature. Speed of the inner ring is 1050 r/min; the radial load is 130 N; and the quantities of lubricating oil are 3 mL/min, 4 mL/min, 5 mL/min, 6 mL/min, and 7 mL/min.
5. The minimum load measured is 124 N while the benchmark is 130 N, and the error of them is 4%.
6. Effect of the Lubricating Oil Cleanliness on the Slip Rate and Temperature. The speed of the inner ring 2100 r/min; the radial load is 120 N; and quantity of lubricating oil 10mL/min.

Slip rate is directly proportional to the surface damage of a roller bearing. There is no direct relationship between the lubricating oil quantity and slip rate.

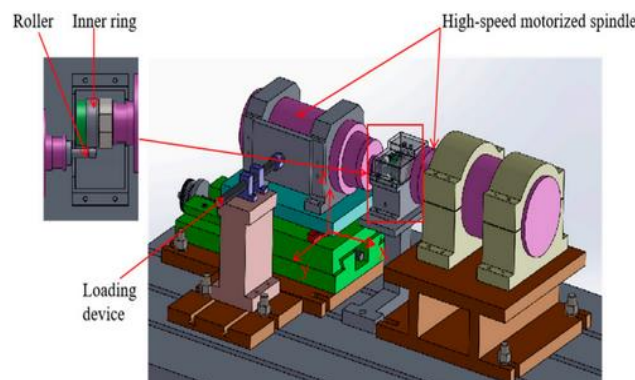

Figure 1. 3D view of test rig model

In test by Her-Terng Yau [2], the test ball bearing used was an SKF 6204 bearing 1.5, 2 and 2.5 m round through holes made in the inner and outer rings. The aim of using Taguchi method was to establish a relationship between vibration signals and each force applied to the bearing during the course of operation. Diagnostic result based on the fault state diameter may have a success rate up to 99% but actually it is only possible to determine the fault which is existent rather than the size. The diagnostic success rate is 92.37% using extension theory and 10% higher in chaos fractal extension theory.

Avinash V. Patil [3], predicted defect on outer race of the roller bearing element acoustic emission method is used. This method has more significance in case of rolling element fault diagnosis. To perform experiment roller bearing which consisted of defect and without defect on the inner face of fit outer race a testing was prepared. An acoustic sensor was used, Pak software was used to record the result. The testing consists off shaft coupled with loading disc supported by 2 bearings Roma a Democrat, 1500 rpm induction motor, flexible coupling, single phase permanent magnet one HP. For applying radial load, a setup of spring balance with leather belt was used. The bearing used was N203M. 50, 100, 150 and 200 were the rpm at which readings were noted. After analyzing the results, it was seen that there is a huge difference between the acoustic emission of healthy and the faulty bearing. It can be concluded by saying the graph defect size is directly operational to acoustic emission amplitude.



Figure 2. Experimental Setup with weights

Defects in ball bearing under different operating condition was evaluated through vibration measurement. 6 sets of ball bearing work considered for testing purpose. First the good bearings are analysed Using FFT analyser and then the faulty bearings are installed in the test rig. Mainly 3 defects are experimentally studied: bearing with inner race, outer race defect rolling element defect. Factors like time domain analysis, frequency domain analysis and root mean square and you used to describe bearing defect. A motor with 150 rpm and a 7.5 kW is used. The length of the shaft is 40 mm dia and 800 mm length which is fixed to the base by 2 bearings placed in between motor and break assembly. Vibration signals are measured with the help of a piezo electric accelerometer. PULSE software is used for vibration analysis. 6 bearings are tested 400, 500, 600, 700, 800 rpm. The pressure applied is 6 bars. The bearings which add fully damaged show greater variation in vibration spectrum. Intensity of vibration in defective bearing can be given by time domain analysis. Whereas the amplitude corresponding to defective frequencies can begiven by frequency domain analysis. By considering the results of Nouby M. Ghazaly [4], one can determine the type and size of the damage that can occur in the bearing.

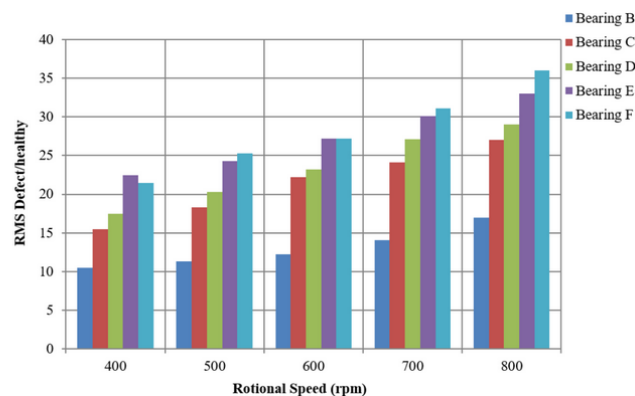

Figure 3. Graph of RPM vs RMS Defects

Sham Kulkarni [5], Peak to peak and RMS parameters are measured at varying speed and load. Also, sensitivity of kurtosis effect with respect to condition monitoring of ball bearing is shown. A test rig is made for the same which consists of a variable speed motor supporting the shaft with the help of bearing. Bearing used for this experiment are DFM-85. To measure the vibration, signal a piezoelectric accelerometer is used which is connected to DEWOSOFT 8- channel FFT analyser, whose output is connected to computer. Defects are created with the help of electric discharge machine for measurement of load a load cell with the capacity of 2000 N is used. Radial load applied on the varying varies from 50N to 200N. 300, 600, 900, 1200 and 1500 rpm were used to collect the Vibration data. radial load of 100 N was kept constant for both defective as well as for healthy bearings. the defects war of size 4.6 Micron and width of 15-degree rough surfaces were measured. The frequency calculated and experimentally achieved are almost same the frequency domain approach gives precise estimation of location of fault. Vibration amplitude level of inner race defected bearing is higher than the amplitude of outer race affected bearing with the increase in load. Speed variation had effect on inner race defect whereas load defect works greater in outer race defect peak to peak amplitude response give the best result followed by peak amplitude and Rams amplitude.

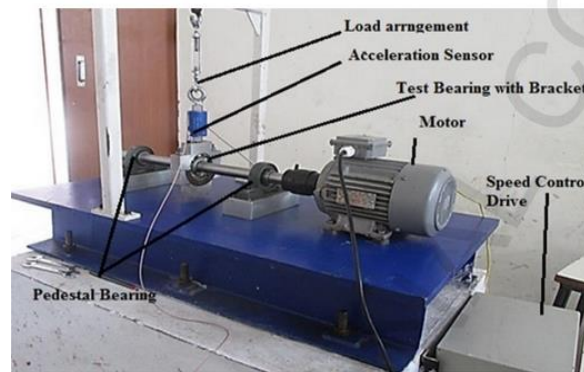

Figure 4. Test Rig Setup

Sailendu Biswal [6], concluded by the development of a bench-top test rig is performed to which to mimic the operating condition of an actual wind turbine. A continuous condition monitoring of various critical components of wind turbine is performed, so as to diagnose the incipient faults in its critical components using Artificial Neural Network (ANN). The nonstationary working condition of gearbox has an impact on the frequency and amplitude of the vibration signal as the wind speed keeps changing time to time. Thus, due to the variable speed rotation the wavelet analysis has been chosen over the Fast Fourier Transform (FFT) and later on development of Artificial Neural Network (ANN) method for fault diagnosis was conducted based on the wavelet analysis. Two cases were considered, and their respective readings were taken using an accelerometer. In the first case the pinion with a tooth root crack and in second case the bearing with axial crack at the inner race were taken into consideration for condition monitoring studies. In order to classify between the healthy and faulty conditions a feed forward network using Gradient Descent with Momentum algorithm was used to train the neural network with five hidden layers. Total 243 data sets were used, for training and testing. Mean Squared Error between output values and target values was considered as an evaluation function. Considering both gear root crack and bearing axial crack vibration features taken together, ANN yielded an accuracy of 92.6% thus effectively classifying the faulty components from the healthy ones. Sakshi Kokil [7], researched Different defect position such as outer race, inner race and ball has its corresponding fault characteristic frequency. Experimental set up consisted of motor driven shaft. That shaft was supported by two supports bearing and one test bearing. Rotor was placed on motor driven shaft. Accelerometer to measure vibration signals were mounted at 4 different positions. Output of accelerometer sent to data acquisition system (DAQ). The Discrete Wavelet Transform (DWT) of the vibration signal computed using the Fast Wavelet Transform (FWT). Time domain and frequency domain data were recorded and compared. The Spectral Analysis using FFT provides information about the frequency content of the raw data but fails to provide time localization of the spectral components. So, to overcome this drawback short term Fourier transform (STFT) and wavelet transform was employed and found that it can clearly detect multi resolution defect.

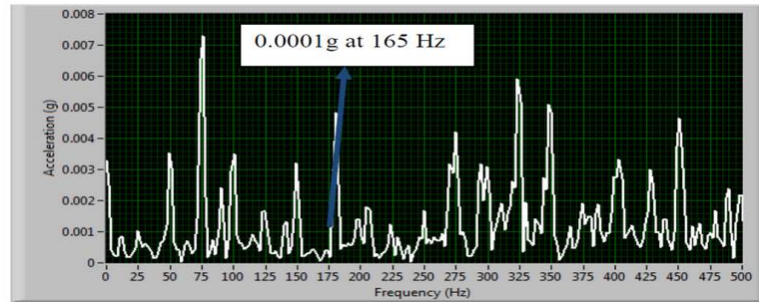

Figure 5. Frequency vs Acceleration Graph when defect present at outer race of 2 mm with load 424N and speed of 1500 rpm

The research of Iulian LUPEA [8], aims to distinguish between healthy state and one or more faulty states of a machine. Feature extraction methods from vibration signals were categorized into statistical time-domain features extraction, frequency-domain features extraction, time-frequency representation, phase-space dissimilarity measurement, complexity measurement and others. The first natural circular frequency is given by, according to the Ritz method, where the mode shape is approximated by a sum of orthogonal functions that satisfy the boundary conditions:

$$\omega_1 = \frac{\pi^2}{l} \sqrt{\frac{EI}{2I(M/2 + m)}}$$

The health states of the observed system can be categorized in seven classes (C0, C1, ..., C6). The first fault (class C1) is obtained by a small eccentric mass attached radially to the central disc. The second fault (class C2) is described by a slightly larger eccentric mass (one M3 nut, added on a longer M3 screw) attached radially to the same central disc. The third system fault (class C3) is referring to the timing belt, more exactly the offset misalignment of sheaves, without eccentric mass on the central disc. The fourth system fault (class C4) is summing up the belt misalignment fault specific to the previous class (C3) with the small eccentric mass added to the disc (specific to class C1). The fifth fault (class C5) is the mentioned belt fault with the larger eccentric mass already used in class C2. For the sixth fault (class C6) belt misaligned fault and any eccentric mass are removed, hence we are at the initial state specific to C0.

An exploration of the effectiveness of a large set of classifiers employed on the three feature sets was performed. The Quadratic Discriminant and the Wide Neural Network, with accuracies of 95% and 94% respectively, applied to the 12 selected features (most of them in frequency domain), are the best suited classifiers for the proposed fault detection task.

T. Narendiranath [9], presented the relative strengths and weaknesses of bearing and developments and trends in improving bearing measurements are documented. Generally, two distinct approaches to exciting the rotor-bearing system for dynamic coefficient identification have been used. One approach, that resembles real machine operation, involves holding the bearing housing rigidly while exciting a moving shaft. The other approach, referred in this work as the inverse method, holds the shaft rigidly while exciting the moving bearing housing. Either is valid in measuring bearing coefficients when performed properly.

Eugenio Brusa [10], developed an innovative bearing test rig architecture is presented, based on the novel concept of "self-contained box". The rotor is horizontal, and a main shaft is included. Only two bearings constrain the shaft. One simply supports the rotor, while a second bearing is monitored, with sensors. Actions apply to the rotor-shaft system directly through two external actuators, along the radial and axial direction, respectively. However, the bearings are indirectly loaded through the shaft bending. Loads are transmitted to the platform and the system might receive some excitations from the platform itself. This configuration can be called as a Mono-Axial rotor, with two bearings and speed control. This setup allows the testing of multiple bearings at the same time, with variable loads in both the radial and axial directions, if a particular design of the loading components of the test rig is implemented. The overall system fills an area of  $3.6 \times 1.7$  m, and covers a height of 1.5 m. It weighs approximately 3000 kg. Self-contained box consists of a reinforced and completely dis-mountable metal housing for the bearings. Vibration and Temperature are independently monitored for each bearing, while the friction torque opposed by bearing to shaft rotation is measured through a single-loaded cell that evaluates the box rotation.

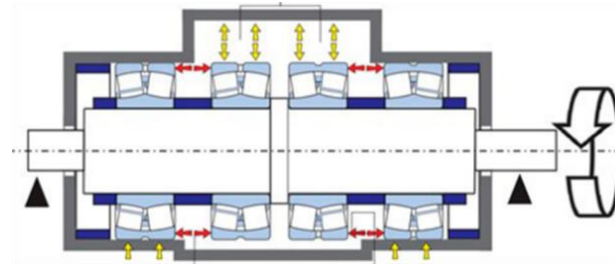

Figure 6. Schematic of internal self-balancing of loads

Chao Ful [11], researched the non-linear vibrations responses of a dual-rotor systems supported on the ball-bearings considering coupling misalignment are investigated with inevitable uncertainties included. The deterministic vibrations response, orbits and frequency spectrum are provided first to exhibit the evolution of the vibrations. Then various physical parameters are studied to reveal the effects of their uncertainty on the nonlinear vibrations at different rpm's. This type of dual-rotor system can be divided into a higher-pressure rotor and a Lower-Pressure rotor, connected by a bearing. The 2 rotors are connected by the inter-shaft bearing no.4 and rotate with different rpm. Numerically is carried out depending on the earlier explained theory. To provide the results, i.e., the nature of the Dual-Rotor system without uncertainty, all the parameters are kept constant, and the motion equations are solved using the Runge–Kutta integration. It is observed that the nonlinear vibrations of the dual-rotor system are more complex at  $100\pi$  rads/s than  $90\pi$  rads/s with the vibrations at bearing no.3 more affected by the ball bearings and misalignment than at bearing no.1. Similarly, the uncertain response bounds are very complex at  $100\pi$  rad/s even for a small uncertainty in the model. Local variations and peaks are seen, which is induced by the nonlinear nature and effects of the uncertainties. This is related to the inherent vibration characteristics of the system at different rpm.

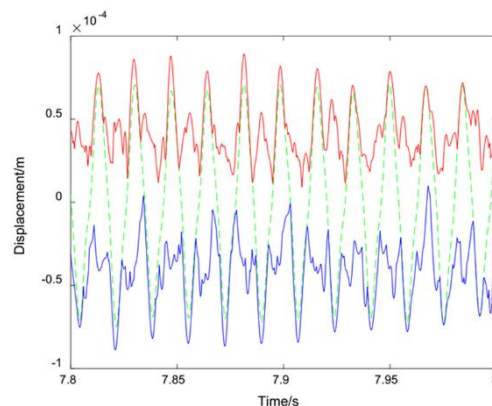

Figure 7. Time vs Displacement with 10% uncertainty in speed ratio

A. M. Umbrajkaar [12], focused on the classification and measure of shaft misalignment under variable load conditions using combined approach on ANN and SVM. The novelty of proposed Classification and Prediction of Shaft Misalignment (CPSM) is to determine the exact type of misalignment and to measure misalignment under variable speed conditions with minimum number of features & the least data size for training. This is done by normalizing vibration signals before feature extraction. The results show that the accuracy of SVM & ANN classifier has been improved due to rank-based feature selection. An accelerometer is placed on the casing of 2<sup>nd</sup> bearing to detect vibration in all three directions viz. Longitudinal ( $V_g$ ), Lateral ( $V_t$ ), and Vertical ( $V_r$ ). The misalignment is induced artificially in set up to visualize a proportional change in Overall Vibration Level (OVL). Wide range of vibrations are observed for a different range of misalignment and rpm conditions. These output signals obtained are normalized in the range of 0.00 to 1.00. In the implementation of CPSM, two sets of observations are recorded. One with varying rpms and constant misalignments & others with varying misalignment and constant speed. Normalized Kurtosis features are used as an input parameter to train ANN which are obtained for different misalignment conditions for all three directions. The various combinations of ANN structures. For training, the Levenberg–Marquardt method is used with tan sigmoid activation function. The selection of the best structure directly depends on the size of training data, neurons in input, hidden, & output layer, & the initial weight is designated to the input signals. In the range of 0 to 0.20 mm, 10 conditions of misalignment are considered for different operating speeds up to 2100.00 rpm, respectively.

Eighteen statistical features are obtained to analyse information in output signal. The Relief algorithm is used to optimize feature selection on rank basis. It is concluded that the error in output of classification and prediction of shaft misalignment is within limit due to normalization, correct wavelet selection on the basis of maximum energy to Shannon entropy ratio, and rank-based feature selection using Relief algorithm.

Youfu Tang [14], utilized different vibration data acquired for determination and validation from four different defects, which are inner race defect, outer race defect, ball defect, and the combination of different bearing element defects. Using statistical parameters, the condition of bearings can be identified using the ball pass frequency outer race (BPFO), ball pass frequency inner race (BPFI), and ball spin frequency (BSF). Sometime-frequency-domain techniques have been produced to diagnose bearing issues in more convoluted rotating machines, where the sound level to vibration signal proportion is low and a substantial number of frequency components are available. Different methods such as singular spectrum analysis (SSA), fuzzy logic systems, artificial neural networks (ANNs), and so on are being utilized to automate the identification and diagnosis of faults in the rolling element bearing. An integration approach based on adaptive waveform decomposition (AWD) and Lempel - Ziv complexity (LZC) was proposed to solve the above problems. For an arbitrary signal, the local frequency is the maximum of the time domain waveform. AWD and EMD can extract three harmonic waveforms from the original signal, which are decomposed from high frequency to low frequency. The fusion method of local frequency and AWD achieves a good adaptive decomposition effect. Lempel - Ziv complexity (LZC) can be used to measure the randomness of time series. LZC features are extracted from rolling bearing vibration signals in time domain under different faults.

Asymmetries in the system cause the deformation caused by misalignment to be different at each angle of rotation. The 2X harmonic is widely accepted as a main symptom of mis alignment, but the author states that harmonic terms can arise from several different sources. Nader Sawalhi [15], developed a model to characterize and identify both angular and parallel misalignment from vibration response (displacement). A simulation model of a three-pin-type flexible coupling was presented, and a comparison between the simulated results and those obtained experimentally was presented. The authors reported that the higher the shaft speed, the more important the harmonic amplitude. They concluded that larger number of pins may smooth out the force variation and also influence harmonic content. The results showed that two times shaft running speed (2X) caused the most misalignment. The authors measured the displacement at the bearing locations and used full spectrum analysis to reveal the whirl nature of the harmonics generated due to the misalignment. After assembling the beams' mass and stiffness matrices, eigenvalue analyses were performed. This section discusses a methodology to measure misalignment forces and a signal processing algorithm to calculate bending stiffness. Coupling stiffness and misalignment modelling. Forces were measured at the bearing location next to the coupling. The misalignment effect can be seen mainly in the form of an increased zero frequency component. Forces were subtracted from the

aligned forces to obtain the net synchronous averaged difference force. The 3X component of the force is caused by the three sets of radial grooves, and only applies to horizontal forces. The mean stiffness of the spiral coupling was measured to be 119.3 kN/m, and the variation of the mean stiffness against the level of misalignment showed a softening effect. Main harmonics appearing in the low frequency are observed at orders 6X, 9X, 10X, 13X, 14X, 15X and 18X. The Lovejoy and spiral coupling amplify the second and third harmonics of the shaft speed. Results from simulated and experimental data show that low-frequency modulation increases with speed fluctuations, and this phenomenon is believed to be the result of a beat.

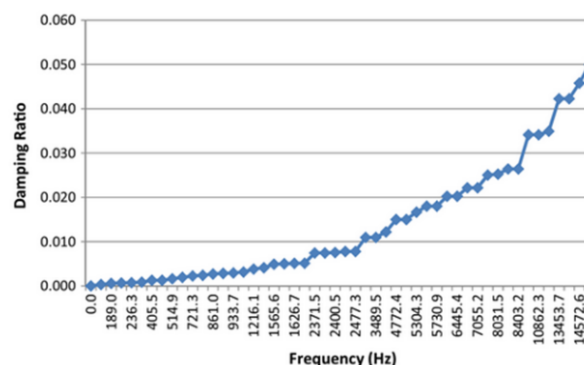

Figure 8. Damping vs first 50 Frequency

The use of artificial intelligence (AI) techniques on motor fault diagnostics is discussed by Shen Zhang [17]. Deep learning is a subset of machine learning that achieves great power and flexibility by learning to represent the world as nested hierarchy of concepts. Deep learning networks can significantly outperform classical ML algorithms on large datasets. Many variations of CNN are employed to tackle the bearing fault diagnosis

challenge using the CWRU dataset. A proposed CNN based on LeNet-5 provides a better feature extraction capability with an astonishing accuracy (99.79%) on test set, which is higher than other deep learning-based methods. A novel architecture based on CNN referred to as "Lifting Net" is implemented to better suppress the impact of speed variations on bearing fault diagnosis. Auto-encoders have been used to automatically extract fault features from the frequency spectrum and effectively classify the bearing health condition. The accuracy of 99.6% reached by a 5-layer auto-encoder based DNN is significantly higher than the 70% of back-propagation based neural networks. A deep belief network (DBN) is a composition of simple unsupervised networks, where each sub-network's hidden layer serves as the visible layer for the next. A multi-sensor vibration data fusion technique is implemented, and a 3-layer DBN is used for classification purposes. A recurrent neural network (RNN) processes the input data in a recurrent behaviour. Long short-term memory (LSTM) is augmented by adding recurrent gates called "forget" gates. A deep convolution GAN (DCGAN) model is proposed to address the class imbalance issue in bearing fault diagnostics. The categorical adversarial autoencoder (CatAAE) is a novel GAN framework that automatically trains an auto-encoder through an adversarial training process. A new framework called WDCNN was proposed based on a CNN architecture with wide kernels to better suppress the high frequency noise.

Deep learning algorithms for bearing fault diagnostics have an average test accuracy of 95%. The accuracy of fault identification nets may suffer significantly under the influence of noise and variation of motor speed and load. If the training set is highly unbalanced, a DL classifier trained with laboratory data will have difficulty identifying bearing faults. Machine learning and deep learning can be used to solve bearing fault diagnostics, but there are still many challenges to overcome.

### 3. CONCLUSION

In this paper, an exhaustive review is presented on the existing literature on bearing fault analysis using machine learning techniques. Bearing failure can happen due to various reasons, out of which prominent parameters studied were radial loads, inner ring speeds, lubricating oil quantities, defects in inner race and outer race. Data was collected based on those parameters with an experimental test rig. Piezoelectric Accelerometers were widely used to measure the vibration amplitude of bearings with defects. After observing accelerometer readings, conclusions were drawn up like there is no direct relationship between the lubricating oil quantity and slip rate, comparison of inner race defective bearing and outer race defective bearing the inner race defective bearing gave a higher amplitude of vibration. Intensity of vibration in defective bearing can be given by time domain analysis. Vibration amplitude level of inner race defected bearing is higher than the amplitude of outer race affected bearing with the increase in load. As a prediction could be made by detection of a particular vibration, different algorithms could be used to predict given bearing failure. Optimised vibration signals are then used by the Chen-Lee chaos system and fractal theory to develop a diagnostic system using the extension theory. The diagnostic success rate is 92.37% using extension theory the diagnostic success rate is 10% higher in chaos fractal extension method rather than traditional FFT and Wavelet methods. In case of variable speed rotation, the wavelet analysis has been chosen over the Fast Fourier Transform (FFT) and later on development of Artificial Neural Network (ANN) method for fault diagnosis was conducted based on the wavelet analysis. ANN yielded an accuracy of 92.6% thus effectively classifying the faulty components from the healthy ones. The Spectral Analysis using FFT provides information about the frequency content of the raw data but fails to provide time localization of the spectral components. So, to overcome this drawback short term Fourier transform (STFT) and wavelet transform was employed and found that it can clearly detect multi resolution defect. Quadratic Discriminant and the Wide Neural Network, with accuracies of 95% and 94% respectively, applied to the 12 selected features (most of them in frequency domain), are the best suited classifiers for the proposed fault detection task.

### REFERENCES

- [1] Juning Li, Jiafan Xue, Ka Han, Qian Wang and Wuge Chen, "Experimental Analysis on Skid Damage of Roller Bearing with the Time-Varying Slip and Temperature Distribution" *Appl. Sci.*, 18 December 2019.
- [2] Her-Terng Yau, Ying-Che Kuo, Chieh-Li Chen, Yu-Chung Li "Ball bearing test-rig research and fault diagnosis investigation" *IET Science, Measurement & Technology*, 2016.
- [3] Avinash V. Patil, Dr. Bimlesh Kumar, "Study Of Fault Diagnosis On Inner Surface Of Outer Race Of Roller Bearing Using Acoustic Emission", *International Research Journal of Engineering and Technology (IRJET)*, June -2017.
- [4] Nouby M. Ghazaly, G. T. Abd el- Jaber, Nadica Stojanovic, "Study Various Defects of Ball Bearings through Different Vibration Techniques", *American Journal of Mechanical Engineering*, 2019.
- [5] Sham Kulkarni, Anand Bewoor, "Vibration based condition assessment of ball bearing with distributed defects", *Journal of Measurements in Engineering*, JUNE 2016.



- [6] Sakshi Kokil, M. M. Shah, S. Y. Gajjal, S. D. Kokil, "Detection of Fault in Rolling Element Bearing Using Condition Monitoring by Experimental Approach", International Journal of Engineering Research & Technology August – 2014.
- [7] Iulian LUPEA, Mihaiela LUPEA, "Fault Detection On A Rotating Test Rig Based On Vibration Analysis And Machine Learning" PROCEEDINGS OF THE ROMANIAN ACADEMY, 2022.
- [8] T. Narendiranath, Babu T. Manvel Raj, T. Lakshmanan "A Review on Application of Dynamic Parameters of Journal Bearing for Vibration and Condition Monitoring" Journal of Mechanics, August 2015
- [9] Eugenio Brusa, Cristiana Delprete, Lorenzo Giorio, Luigi Gianpio Di Maggio and Vittorio Zanella "Design of an Innovative Test Rig for Industrial Bearing Monitoring with Self-Balancing Layout" Machines 2022.
- [10] Chao Fu1, Kuan Lu1, Yongfeng Yang, Zhongliang Xie, Anbo Ming1, "Nonlinear Vibrations of an Uncertain Dual Rotor Rolling Bearings System with Coupling Misalignment", Journal of Nonlinear Mathematical Physics, 2022.
- [11] A. M. Umbrajkaar, A. Krishnamoorthy,1 and R. B. Dhumale2 "Vibration Analysis of Shaft Misalignment Using Machine Learning Approach under Variable Load Conditions" Shock and Vibration, 2020.
- [12] Chandrabhanu Malla, Isham Panigrahi1, "Review of Condition Monitoring of Rolling Element Bearing Using Vibration Analysis and Other Technique, Journal of Vibration Engineering & Technologies, 15 May 2019.
- [13] Youfu Tang, Feng Lin, and Qian Zou, "Complexity Analysis of Time-Frequency Features for Vibration Signals of Rolling Bearings Based on Local Frequency", Shock and Vibration, 2019.
- [14] Nader Sawalhi, Suri Ganeriwala, Máté Tóth, "Parallel misalignment modeling and coupling bending stiffness measurement of a rotor-bearing system", Applied Acoustics, 2017.
- [15] Vivek Parmar, V Huzur Saran, SP Harsha, "Effect of dynamic misalignment on the vibration response, trajectory followed, and defect-depth achieved by the rolling-elements in a double-row spherical rolling-element bearing", Mechanism and Machine Theory, 20 April 2021.
- [16] Shen Zhang, Shibo Zhang, Bingnan Wang, Thomas G. Habetler, "Deep Learning Algorithms for Bearing Fault Diagnostics – A Comprehensive Review", 6 Feb 2020.
- [17] Duy-Tang Hoang, Hee-Jun Kang, "A Survey on Deep Learning based Bearing Fault Diagnosis", Neurocomputing, 10 June 2018.
- [18] Jiedi Sun, Changhong Yan, and Jiangtao Wen, "Intelligent Bearing Fault Diagnosis Method Combining Compressed Data Acquisition and Deep Learning", IEEE TRANSACTIONS ON INSTRUMENTATION AND MEASUREMENT, September 4, 2017.
- [19] Rafia Nishat Toma, Alexander E. Prosvirin and Jong-Myon Kim, "Bearing Fault Diagnosis of Induction Motors Using a Genetic Algorithm and Machine Learning Classifiers", Sensors, 28 March 2020.
- [20] Miguel Delgado, Giansalvo Cirrincione, Antonio Garcia Espinosa, Juan Antonio Ortega, Humberto Henao "Bearing Faults Detection by a Novel Condition Monitoring Scheme based on Statistical-Time Features and Neural Networks", August 26, 2012
- [21] Sailendu Biswal, "Design and Development of a Wind Turbine Test Rig for Condition Monitoring Studies" International Conference on Industrial Instrumentation and Control, 2015.
- [22] Y.S. Lee, C.W. Lee, "Modelling and vibration analysis of misaligned rotor-ball bearing systems", Journal of Sound and Vibration, 1999.
- [23] Zijian Qiao, Zhengrong Pan, "SVD principle analysis and fault diagnosis for bearings based on the correlation coefficient", Measurement Science and Technology, 2015.
- [24] P K Kankar, Satish C Sharma, S P Harsha, "Rolling element bearing fault diagnosis using autocorrelation and continuous wavelet transform", Journal of Vibration and Control, 2011.
- [25] Mao Kunli, Wu Yunxin, "Fault Diagnosis of Rolling Element Bearing Based on Vibration Frequency Analysis", Third International Conference on Measuring Technology and Mechatronics Automation, 2011.